

# ATN

**NEW**

## **PIAF 1010**

Self-propelled mast boom  
track-mounted



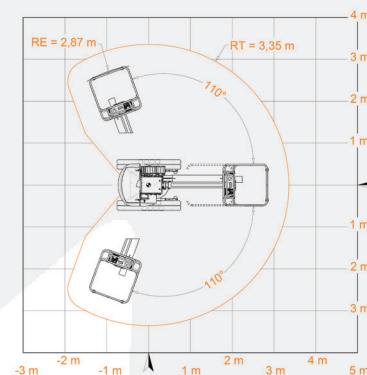
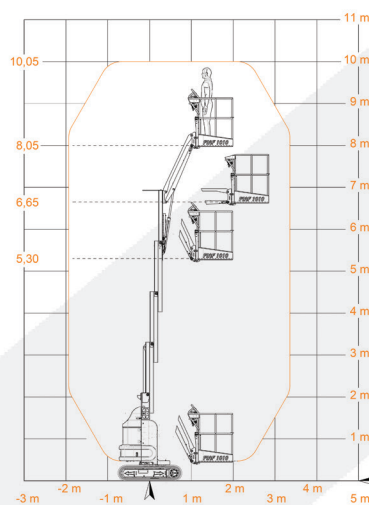
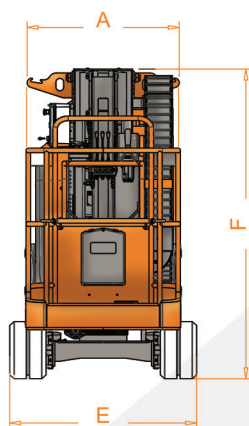
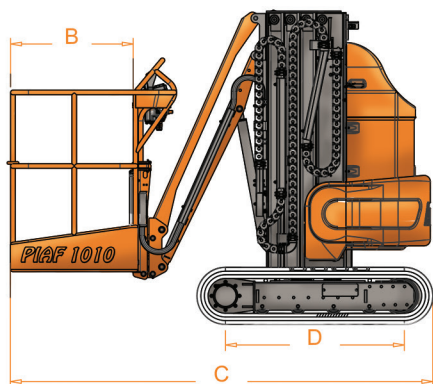

# PIAF 1010 Tracks

## ADVANTAGES

- Effectiveness thanks to the 2 x 110 ° tower rotation.
- Multi-function operation on all indoor and outdoor sites.
- Flexible and easy movement with the progress sideways hydraulic joystick command.
- Manoeuvrability.
- Zero turning radius.
- Easy on fragile ground.
- Designed for intensive use.

## STANDARD FEATURES

- Non-marking rubber tracks.
- Progressive hydraulic movement commands.
- Hydraulic joystick sideways movement commands.
- 560 Ah 24 V traction batteries with centralised filling system.
- HF 85 A onboard charger.
- Two movement speeds.
- Slings rings.
- Emergency hand pump.
- Battery indicator with 80% discharge cut-off.
- Tilt indicator with buzzer.
- Overload sensor.
- Anti-tipping system.
- Hour meter.
- Extra-wide platform.

## OPTIONS

- Compressed air line.
- 220V socket in the platform.
- Automatic power cut-off if tilt value > 5°.
- Flashing light.
- Motion alarm.
- Special customer paint colour(s).



This product complies with European regulations in force (EN 280). Due to our constant improvement policy, ATN reserves the right to many any modifications without any prior notice.



Zl. Guillaume Mon Amy 47400 FAUILLET - FRANCE  
 Tel.: + 33 (0)553 798 320 - Fax: + 33 (0)553 880 107  
 email: contact@atnplatforms.com

	1010
Working height	10.05 m
Floor height	8.05 m
Maximum offset	3.35 m
Payload	200 kg
Turret rotation	2 x 110°
<b>A</b> Platform width	0.90 m
<b>B</b> Platform length	0.80 m
<b>C</b> Length (stowed)	2.70 m
<b>D</b> Wheelbase	1.20 m
<b>E</b> Width	1.20 m
<b>F</b> Height (stowed)	2.12 m
Turning radius	0

Gradeability (stowed)	30%
Maximum tilt	3°
Maximum speed (machine stowed)	1.6 km/h
Maximum speed (machine stowed)	0.9 km/h
Total weight	2780 kg
Ground bearing pressure	0.7 kg / cm <sup>2</sup>

## CACES R 386 3B

